

# LAUDA

## COOLING THERMOSTATS

LAUDA



### Specific application examples

- Sample preparation in chemistry and pharmacy
- Functional testing of electronic components
- Test of slide bearings
- Valve testing
- Stress test
- Notch bending test
- Expansion testing
- Brookfield test
- Semi-conductor coating



# LAUDA ECO

From -50 to 200 °C: Cooling thermostats for economic temperature control in the lab



## Impressive range of capabilities coupled with easy operation

The ECO thermostats are available in Silver (LCD) or Gold (color TFT display) models with a large number of interface modules as accessories. The circulation pump can be adjusted to six levels. The comprehensive model portfolio offers devices with cooling capacities of 180 to 700 watts and minimum temperatures of -15 to -50°C. The devices of the LAUDA ECO series with the highest performance work with an energy-saving LAUDA SmartCool system, which automatically adjusts the cooling capacity to the required operating status.

The low-temperature thermostats are also available with natural refrigerants as standard for extra environmentally-friendly operation.



Plain text menu guidance on a monochrome LCD (Silver) or color TFT display (Gold) for easy and intuitive operation



Standard pump connections for temperature control of external applications

## COOLING PERFORMANCE Heat transfer liquid: Ethanol, bath closed

Bath temperature °C

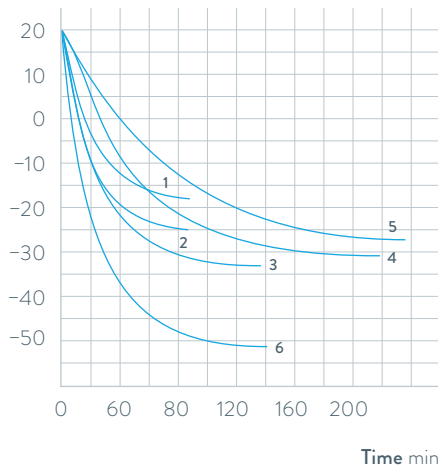

- 1 RE 415 G
- 2 RE 420 G
- 3 RE 630 G
- 4 RE 1225 G
- 5 RE 2025 G
- 6 RE 1050 G

## Important functions

- Integrated programmer for automating temperature profiles
- Adjustment of flow rate switch for internal/external circulation, can be actuated from exterior during operation
- USB interface as standard

## Included accessories

Bath cover, pump connections, closing plugs

## Further accessories

Tubing, interface modules (P. 69)

All technical data and power supply variants can be found in the ›Technical data‹ section.

More at [www.lauda.de/1738](http://www.lauda.de/1738)



## LAUDA ECO

The cooling thermostats come with a bath cover and pump connections as standard. A drain tap on the back side of the device makes changing the heat transfer liquid easy and safe.



# LAUDA Cooling thermostats

## Device type overview

LAUDA Alpha / Page 60

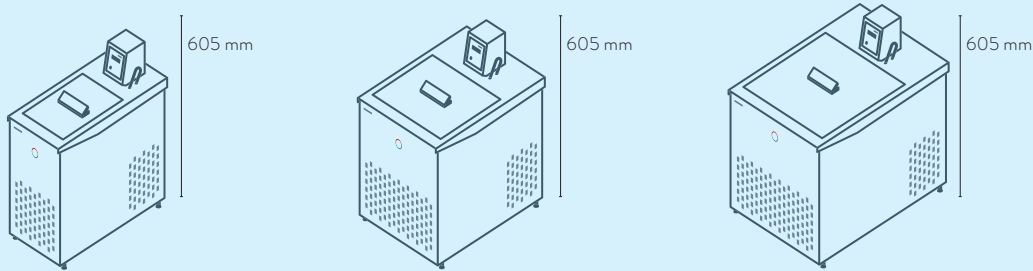

RA 8

RA 12

RA 24

LAUDA ECO / Page 62

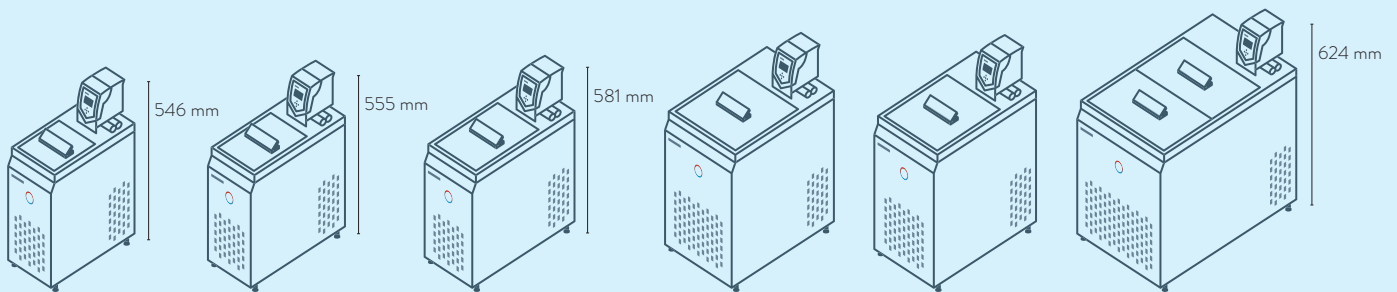

RE 415 S  
RE 415 G

RE 420 S  
RE 420 G

RE 630 S  
RE 630 G

RE 1050 S  
RE 1050 G

RE 1225 S  
RE 1225 G

RE 2025 S  
RE 2025 G

LAUDA PRO / Page 64

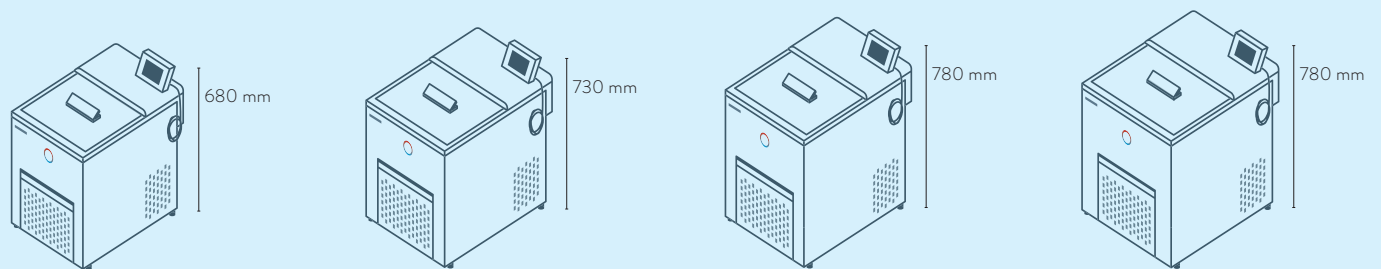

RP 2040 C  
RP 2045 C

RP 3035 C

RP 1090 C

RP 2090 C  
RP 10100 C

LAUDA Proline Kryomats / Page 66

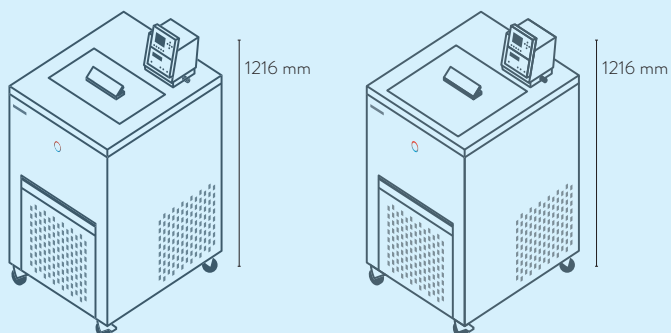

RP 3090 C / RP 3090 CW

RP 4050 C / RP 4050 CW  
RP 4090 C / RP 4090 CW

# LAUDA Cooling thermostats

## More characteristics

LAUDA Alpha / Page 60

### PUMP CHARACTERISTIC Water

Pressure bar

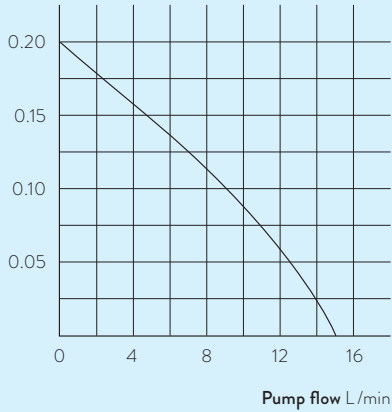

LAUDA ECO / Page 62

### COOLING PERFORMANCE According to DIN 12876

Bath temperature °C

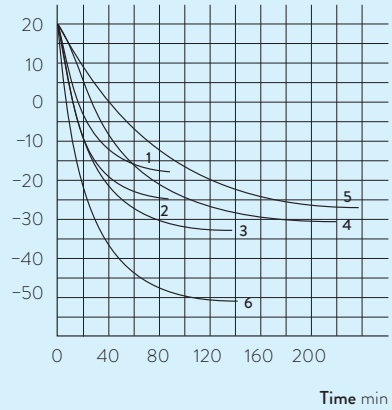

- 1 RE 415 S
- 2 RE 420 S
- 3 RE 630 S
- 4 RE 1225 S
- 5 RE 2025 S
- 6 RE 1050 S

### PUMP CHARACTERISTIC Water

Pressure bar

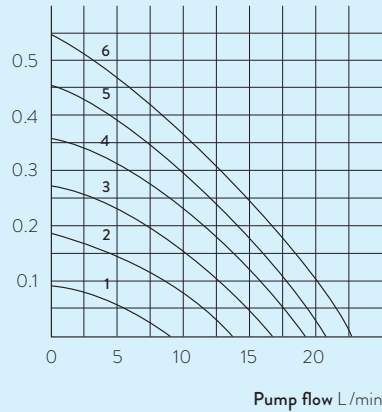

- 1 Step 1
- 2 Step 2
- 3 Step 3
- 4 Step 4
- 5 Step 5
- 6 Step 6

LAUDA Proline Kryomats / Page 66

### COOLING PERFORMANCE According to DIN 12876

Bath temperature °C

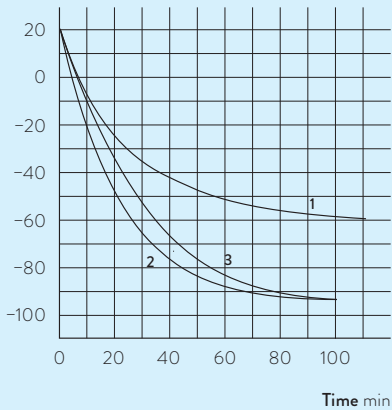

- 1 RP 4050 CW
- 2 RP 3090 CW
- 3 RP 4090 CW

# LAUDA Cooling thermostats

## Interfaces

	Pt 100 (1)	Pt 100 (2)	USB	Ethernet	RS 232 / 485	Analog	Namur contact	D-SUB contact	PROFIBUS	EtherCAT M8	EtherCAT RJ 45	Number of module slots, large	Number of module slots, small
LAUDA Alpha / Page 60	-	-	-	-	-	-	-	-	-	-	-	-	-
LAUDA ECO / Page 62	Z	-	S	Z	Z	Z	Z	Z	Z	Z	Z	1	1
LAUDA PRO / Page 64	S	-	S	S	Z	Z	Z	Z	Z	Z	Z	1	-
LAUDA Proline Kryomat / Page 66	S	-	-	Z	S	Z	Z	Z	Z	Z	Z	2	-

S = Series standard

Z = Available as an accessory



LRZ 912  
Analog module



LRZ 913  
RS 232/485 interface



LRZ 914  
Contact module with single input and single output (NAMUR)



LRZ 915  
Contact module with 3 inputs and 3 outputs



LRZ 917  
Profibus module



LRZ 918  
Pt100/Li bus module, small cover



LRZ 921  
Ethernet module



LRZ 922  
EtherCAT module with M8 connection

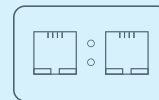

LRZ 923  
EtherCAT module with RJ45 connection



LRZ 925  
External Pt100/LiBus-module, large cover

# LAUDA Cooling thermostats

## Function overview

Operating element	Alpha	ECO S	ECO G	PRO Base	PRO Command Touch	Proline Kryomats
Display	7-Segment	LCD mono	TFT	OLED	TFT	LCD mono
Mode of operation	3-button	3-button softkey	Cursor softkey	Cursor softkey	Multi-touch	Cursor softkey
Removable control	-	-	-	✓	✓	✓
User management	-	-	-	-	✓	-
Data logging, export to USB stick	-	-	-	-	✓	-
1-point calibration	✓	✓	✓	✓	✓	✓
2-point calibration	-	-	-	✓	✓	-
Programmer, programs/segments	-	1 / 20	5 / 150	1 / 20	100 / 5000	5 / 150
Programmer, tolerance range function	-	✓	✓	✓	✓	✓
Ramp function	-	-	-	-	✓	✓
Timer function	-	-	-	-	✓	✓
Countdown function	✓	-	-	-	✓	✓
Graphic temperature profile display	-	-	✓	-	✓	✓
Adjustable bypass	-	-	-	-	-	✓
Level indicator (digital)	-	-	-	✓	✓	✓
Standby timer	-	✓	✓	✓	✓	✓
Low-level alarm	✓	✓	✓	✓	✓	✓
Drain tap	-	✓	✓	✓	✓	✓
Drain screw	✓	-	-	-	-	-



# LAUDA Cooling thermostats

Technical data according to DIN 12876 standard

Device type	Working temperature range °C	Temperature stability ±K	Safety fittings	Heater power max. kW	Cooling output kW														Pump type	Pump pressure max. bar
					20 °C	10 °C	0 °C	-10 °C	-20 °C	-25 °C	-30 °C	-40 °C	-50 °C	-60 °C	-70 °C	-80 °C	-90 °C	-100 °C		
<b>LAUDA Alpha / Page 60</b>																				
RA 8	-25 ... 100	0.05	I, NFL	1.5	0.23	-	0.16	-	0.08	-	-	-	-	-	-	-	-	-	D	0.2
RA 12	-25 ... 100	0.05	I, NFL	1.5	0.33	-	0.26	-	0.08	-	-	-	-	-	-	-	-	-	D	0.2
RA 24	-25 ... 100	0.05	I, NFL	1.5	0.43	-	0.33	-	0.08	-	-	-	-	-	-	-	-	-	D	0.2
<b>LAUDA ECO / Page 62</b>																				
RE 415 S	-15 ... 200	0.02	III, FL	2.0	0.18 <sup>1</sup>	-	0.12 <sup>1</sup>	-	-	-	-	-	-	-	-	-	-	-	V	0.55
RE 420 S	-20 ... 200	0.02	III, FL	2.0	0.20 <sup>1</sup>	-	0.15 <sup>1</sup>	-	0.03 <sup>1</sup>	-	-	-	-	-	-	-	-	-	V	0.55
RE 630 S	-30 ... 200	0.02	III, FL	2.0	0.30 <sup>1</sup>	-	0.24 <sup>1</sup>	-	0.10 <sup>1</sup>	-	0.02 <sup>1</sup>	-	-	-	-	-	-	-	V	0.55
RE 1050 S	-50 ... 200	0.02	III, FL	2.0	0.70 <sup>1</sup>	-	0.60 <sup>1</sup>	-	0.35 <sup>1</sup>	-	0.19 <sup>1</sup>	0.10 <sup>1</sup>	0.02 <sup>1</sup>	-	-	-	-	-	V	0.55
RE 1225 S	-25 ... 200	0.02	III, FL	2.0	0.30 <sup>1</sup>	-	0.24 <sup>1</sup>	-	0.09 <sup>1</sup>	0.04 <sup>1</sup>	-	-	-	-	-	-	-	-	V	0.55
RE 2025 S	-25 ... 200	0.02	III, FL	2.0	0.30 <sup>1</sup>	-	0.23 <sup>1</sup>	-	0.06 <sup>1</sup>	0.03 <sup>1</sup>	-	-	-	-	-	-	-	-	V	0.55
RE 415 G	-15 ... 200	0.02	III, FL	2.6	0.18 <sup>1</sup>	-	0.12 <sup>1</sup>	-	-	-	-	-	-	-	-	-	-	-	V	0.55
RE 420 G	-20 ... 200	0.02	III, FL	2.6	0.20 <sup>1</sup>	-	0.15 <sup>1</sup>	-	0.03 <sup>1</sup>	-	-	-	-	-	-	-	-	-	V	0.55
RE 630 G	-30 ... 200	0.02	III, FL	2.6	0.30 <sup>1</sup>	-	0.24 <sup>1</sup>	-	0.10 <sup>1</sup>	-	0.02 <sup>1</sup>	-	-	-	-	-	-	-	V	0.55
RE 1050 G	-50 ... 200	0.02	III, FL	2.6	0.70 <sup>1</sup>	-	0.60 <sup>1</sup>	-	0.35 <sup>1</sup>	-	0.19 <sup>1</sup>	0.10 <sup>1</sup>	0.02 <sup>1</sup>	-	-	-	-	-	V	0.55
RE 1225 G	-25 ... 200	0.02	III, FL	2.6	0.30 <sup>1</sup>	-	0.24 <sup>1</sup>	-	0.09 <sup>1</sup>	0.04 <sup>1</sup>	-	-	-	-	-	-	-	-	V	0.55
RE 2025 G	-25 ... 200	0.02	III, FL	2.6	0.30 <sup>1</sup>	-	0.23 <sup>1</sup>	-	0.06 <sup>1</sup>	0.03 <sup>1</sup>	-	-	-	-	-	-	-	-	V	0.55

<sup>1</sup>Pump output step 2

Pump flow max. pressure L/min	Pump connection thread mm	Nipples Øe	Bath volume min. L	Bath volume max. L	Bath opening (W x D) mm	Bath depth mm	Usable depth mm	Height top of bath mm	Dimensions (W x D x H) mm	Weight kg	Power supply V; Hz	Loading max. kW	Part Number	Device type
15.0	N/A	13	5.0	7.5	235×500	160	140	450	235×500×605	28.5	230 V; 50 Hz & 220 V; 60 Hz	1.8	L000638	RA 8
15.0	N/A	13	9.5	14.5	365×500	160	140	450	365×500×605	37.0	230 V; 50 Hz & 220 V; 60 Hz	1.8	L000639	RA 12
15.0	N/A	13	14.0	22.0	415×605	160	140	450	415×605×605	43.0	230 V; 50 Hz & 220 V; 60 Hz	1.8	L000640	RA 24
22.0	-	13	3.3	4.0	180×350	160	140	365	180×350×546	20.0	230 V; 50 Hz	2.2	L002815	RE 415 S
22.0	-	13	3.3	4.0	180×396	160	140	374	180×396×555	22.0	230 V; 50 Hz	2.2	L001333	RE 420 S
22.0	-	13	4.6	5.7	200×430	160	140	400	200×430×581	27.0	230 V; 50 Hz	2.3	L001335	RE 630 S
22.0	-	13	8.0	10.0	280×440	160	140	443	280×440×624	34.0	230 V; 50 Hz	2.5	L001336	RE 1050 S
22.0	-	13	9.3	12.0	250×435	200	180	443	250×435×624	31.0	230 V; 50 Hz	2.3	L001337	RE 1225 S
22.0	-	13	14.0	20.0	350×570	160	140	443	350×570×624	38.0	230 V; 50 Hz	2.3	L001338	RE 2025 S
22.0	M16×1	13	3.3	4.0	180×350	160	140	365	180×350×546	20.5	230 V; 50 Hz	2.8	L002816	RE 415 G
22.0	M16×1	13	3.3	4.0	180×396	160	140	374	180×396×555	22.0	230 V; 50 Hz	2.8	L001339	RE 420 G
22.0	M16×1	13	4.6	5.7	200×430	160	140	400	200×430×581	24.0	230 V; 50 Hz	2.9	L001341	RE 630 G
22.0	M16×1	13	8.0	10.0	280×440	160	140	443	280×440×624	34.0	230 V; 50 Hz	3.1	L001342	RE 1050 G
22.0	M16×1	13	9.3	12.0	250×435	200	180	443	250×435×624	31.0	230 V; 50 Hz	2.9	L001343	RE 1225 G
22.0	M16×1	13	14.0	20.0	350×570	160	140	443	350×570×624	40.0	230 V; 50 Hz	2.9	L001344	RE 2025 G

# LAUDA Cooling thermostats

## Power supply variants

Device type	Power supply V; Hz	Heater power max. kW	Loading max. kW	Plug code*	Part Number	Device type	Power supply V; Hz	Heater power max. kW	Loading max. kW	Plug code*	Part Number
<b>LAUDA Alpha / Page 60</b>											
RA 8	100 V; 50/60 Hz	1.0	1.3	14	L000653	RA 24	115 V; 60 Hz	1.2	1.5	14	L000652
RA 8	115 V; 60 Hz	1.2	1.5	14	L000650	RA 24	230 V; 50 Hz & 220 V; 60 Hz	1.4	1.8	17	L000640
RA 8	230 V; 50 Hz & 220 V; 60 Hz	1.4	1.8	17	L000638						
RA 12	115 V; 60 Hz	1.2	1.5	14	L000651						
RA 12	230 V; 50 Hz & 220 V; 60 Hz	1.4	1.8	17	L000639						
<b>LAUDA ECO / Page 62</b>											
RE 415 S	115 V; 60 Hz	1.3	1.4	14	L001433	RE 1050 S	100 V; 50/60 Hz	1.0	1.5	14	L001465
RE 415 S	220 V; 60 Hz	1.8	2.1	3	L001405	RE 1050 S	115 V; 60 Hz	1.3	1.4	14	L001437
RE 415 S	220 V; 60 Hz	1.8	2.1	2	L002073	RE 1050 S	220 V; 60 Hz	1.8	2.4	3	L001409
RE 415 G	115 V; 60 Hz	1.3	1.4	14	L001440	RE 1050 S	220 V; 60 Hz	1.8	2.4	2	L002077
RE 415 G	220 V; 60 Hz	2.4	2.6	3	L001412	RE 1050 G	100 V; 50/60 Hz	1.0	1.5	14	L001472
RE 415 G	220 V; 60 Hz	2.4	2.6	2	L002080	RE 1050 G	115 V; 60 Hz	1.3	1.4	14	L001444
RE 420 S	100 V; 50/60 Hz	1.0	1.2	14	L001462	RE 1050 G	220 V; 60 Hz	2.4	2.9	3	L001416
RE 420 S	115 V; 60 Hz	1.3	1.4	14	L001434	RE 1225 S	100 V; 50/60 Hz	1.0	1.3	14	L001466
RE 420 S	220 V; 60 Hz	1.8	2.1	3	L001406	RE 1225 S	115 V; 60 Hz	1.3	1.4	14	L001438
RE 420 S	220 V; 60 Hz	1.8	2.1	2	L002074	RE 1225 S	220 V; 60 Hz	1.8	2.1	2	L002078
RE 420 G	100 V; 50/60 Hz	1.0	1.2	14	L001469	RE 1225 S	220 V; 60 Hz	1.8	2.1	3	L001410
RE 420 G	115 V; 60 Hz	1.3	1.4	14	L001441	RE 1225 G	100 V; 50/60 Hz	1.0	1.3	14	L001473
RE 420 G	220 V; 60 Hz	2.4	2.6	3	L001413	RE 1225 G	115 V; 60 Hz	1.3	1.4	14	L001445
RE 630 S	100 V; 50/60 Hz	1.0	1.3	14	L001464	RE 1225 G	220 V; 60 Hz	2.4	2.7	3	L001417
RE 630 S	115 V; 60 Hz	1.3	1.4	14	L001436	RE 2025 S	100 V; 50/60 Hz	1.0	1.3	14	L001467
RE 630 S	220 V; 60 Hz	1.8	2.1	3	L001408	RE 2025 S	115 V; 60 Hz	1.3	1.4	14	L001439
RE 630 S	220 V; 60 Hz	1.8	2.1	2	L002076	RE 2025 S	220 V; 60 Hz	1.8	2.1	2	L002079
RE 630 G	100 V; 50/60 Hz	1.0	1.3	14	L001471	RE 2025 S	220 V; 60 Hz	1.8	2.1	3	L001411
RE 630 G	115 V; 60 Hz	1.3	1.4	14	L001443	RE 2025 G	100 V; 50/60 Hz	1.0	1.3	14	L001474
RE 630 G	220 V; 60 Hz	2.4	2.7	2	L002083	RE 2025 G	115 V; 60 Hz	1.3	1.4	14	L001446
RE 630 G	220 V; 60 Hz	2.4	2.7	3	L001415	RE 2025 G	220 V; 60 Hz	2.4	2.7	3	L001418

\*All data for the plug codes can be found on page 162

# Power plugs

## Overview

Image	Plug code	Description	Image	Plug code	Description	Image	Plug code	Description
	2	CEE7/7 angled (EU, Schuko)		3	NEMA 6-20P (USA)		4	NEMA 5-20P (USA)
	5	GB2099 (CN)		6	BS1363 angled (UK)		7	IEC 60309, (blue), ›Caravan
	8	SEV 1011, SEV 5934/2 (CH, T23)		9	AS/NSZ 3112 (AUS)		10	NBR 14136 (BR)
	14	NEMA 5-15P (USA)		17	CEE7/7 straight (EU, Schuko)		21	IEC 60309, 5-pin, CEE, red, 16 A
	22	IEC 60309, 5-pin, CEE, red, 32 A		23	IEC 60309, 5-pin, CEE, red, 63 A		25	NEMA 5-15P (Japan)
	26	SEV 1011, SEV 5934/2 (CH, T12)		31	Mains cable without plug (HAR), Harmonized cable (DIN VDE 0281/DIN VDE 0282/DIN VDE 0292)		32	Mains cable without plug (AWG), American Wire Gauge, abbreviation AWG
	33	NEMA L16-30P twist lock; 30 A 480 V; 30 A, 3L+N+PE		34	NEMA L16-20P twist lock; 20 A 480 V; 20 A, 3L+N+PE		35	AS/NSZ 3112, SAA/3 (AUS) Australia, 250 V; 10 A
	36	NEMA 6-15P (USA) USA, 250 V; 15 A		37	NBR 14136, BR/3 (BR) Brazil, 250 V; 10 A		38	NEMA L15-30P twist lock; 30 A USA, 250 V; 30 A, 3L+PE
	40	NEMA L15-20P twist lock; 20 A USA, 250 V; 20 A, 3L+PE		42	Two mains cables with socket 6 and 8		43	Two mains cables with socket 6 and 17

# LAUDA Accessories

Individual solutions, down to the finest detail

## Tailored to your requirements

It makes no difference whether it concerns an optimized sample holder, improved handling or storage, mechanical accessories facilitate the daily temperature control, shaking or cultivating work. A wide variety of hose material in various cross-sections, optimized for the temperature range or also insulated as needed is the basis for the hydraulic connection of constant temperature equipment to applications. Adapters, distributors and taps provide flexibility. Remote controls, interfaces and through-flow control systems individually extend the connectivity, the range of functions and the operating convenience.

### Electrical and electronic accessories:

- Flow controllers
- Flow control instruments
- Remote controls
- Solenoid valves
- Interface modules
- Temperature sensors
- Connecting cables and sockets



### Hose material:

- Hose sets
- Polymer hoses
- Corrugated metal hoses
- Insulating hoses



### Hydraulic components:

- Shut-off valves
- Adapters and fittings
- Cooling coils and heat exchangers
- Filter systems
- Distributors



### Mechanical accessories:

- Bath covers
- Bath vessels
- Fastening components and mounts
- Boxes and baskets
- Racks
- Rising platforms
- Platforms
- Trays



### Consumables:

- Filter cartridges



### Documentation:

- Certificates

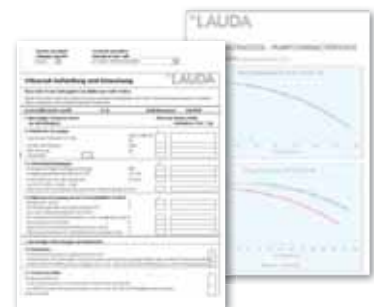

Request the comprehensive LAUDA accessories brochure at [info@lauda.de](mailto:info@lauda.de)

More at [www.lauda.de/1784](http://www.lauda.de/1784)

# LAUDA Heat transfer liquids

## For safe and reliable operation of your thermostats

**Highly accurate temperature control at extreme temperatures, reliability and long-term operational stability for a long service life of the thermostats.**

The right choice of heat transfer liquid is of critical importance for the safe and reliable operation of thermostats, circulation chillers or water baths. Thanks to our many decades of experience, we are able to offer optimum heat transfer liquids for LAUDA thermostats and other brands. Prices of heat transfer liquids can be found in our price list, which we will gladly send you on request.

Designation	Open / half-open systems °C						Closed systems with cold oil overlay (Integral XT) °C						Part Number 5L/10L/20L
	-100 °C	-50 °C	0 °C	100 °C	200 °C	300 °C	-100 °C	-50 °C	0 °C	100 °C	200 °C	300 °C	
Aqua 90			5 °C		90 °C								LZB 120/LZB 220/LZB 320
Kryo 95 Silicone oil	-95 °C				60 °C		-95 °C					160 °C	LZB 130/LZB 230/LZB 330
Kryo 70 Silicone oil							-70 °C					220 °C	LZB 127/LZB 227/LZB 327
Kryo 65							-65 °C					140 °C	LZB 118/LZB 218/LZB 318
Kryo 60 Silicone oil		-60 °C			60 °C								LZB 102/LZB 202/LZB 302
Kryo 51 Silicone oil		-50 °C											LZB 121/LZB 221/LZB 321
Kryo 30			-30 °C			90 °C			-30 °C			90 °C	LZB 109/LZB 209/LZB 309
Kryo 20 Silicone oil			-20 °C			170 °C							LZB 116/LZB 216/LZB 316
Therm 160			60 °C			160 °C							LZB 106/LZB 206/LZB 306
Therm 180 Silicone oil			0 °C			180 °C							LZB 114/LZB 214/LZB 314
Therm 250 Silicone oil			50 °C			250 °C							LZB 122/LZB 222/LZB 322
Ultra 350			30 °C			200 °C			30 °C			350 °C	LZB 107 / - / -

Note: LAUDA Integral P may only be operated with non-combustible media (Kryo 30).  
The temperature range of Kryo 30 is extended from -40 to 140 °C here.

Request the comprehensive LAUDA heat transfer liquid brochure at [info@lauda.de](mailto:info@lauda.de)

More at [www.lauda.de/1782](http://www.lauda.de/1782)



Tel. +41 44 456 33 33  
[igz@igz.ch](mailto:igz@igz.ch)