

# LAUDA CIRCULATION AND PROCESS THERMOSTATS

°LAUDA

## Specific application examples

---

- Refractometer
- Polarimeter
- Single-use bioreactors
- Extruder for food production
- Micro reactors
- Responsive control in chemical/pharmaceutical surroundings
- Climate chambers
- Space simulation
- Electric mobility; battery testing
- Test rigs
- Stress test
- Crystallization regulation
- Freeze-drying
- Micro structures
- Coating plants



# LAUDA LOOP

The compact, lightweight circulation thermostat for external applications from 4 to 80 °C

4°C  80°C

## Extremely versatile, flexibly usable thermo-electric circulation thermostat

The LAUDA LOOP circulation thermostat is sure to impress with its constant temperature range between 4 and 80 °C. Its compact construction and low weight, as well as wide voltage input range of 100 to 240 volts, make it possible to put it to use flexibly and spontaneously anywhere in the world – the ›Plug and Play‹ setup with quick-fit couplings makes it especially easy to use. The intuitive three-button softkey operation and simple menu navigation in five available languages via the well-lit, high-contrast OLED display make using the device a breeze.



Simple three-button controls with OLED display



Standard-issue RS 232 interface for system integration into processes

## PUMP CHARACTERISTIC Water

Pressure bar

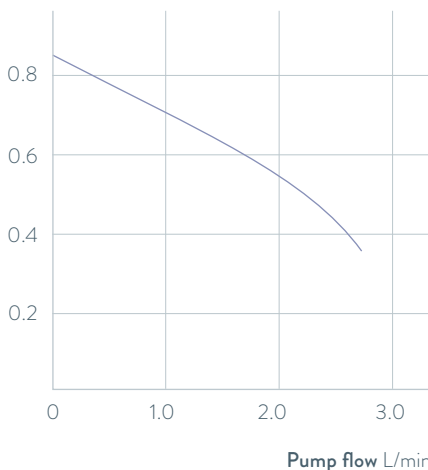

## Important functions

- Pump connections with quick-fit couplings for easy consumer changes
- Can be operated with non-flammable liquids (water, water/glycol)
- Cooling technology free of coolant ensures silent, low-vibration operation

## Included accessories

Hose nozzles for pump connections

## Further accessories

Tubing

All technical data and power supply variants can be found in the ›Technical data‹ section.

More at [www.lauda.de/1748](http://www.lauda.de/1748)



### LAUDA LOOP

The L100 and L250 air-cooled device types achieve a cooling capacity of 120 and 250 watt. The devices are primarily for use at constant temperatures with low power requirements. Both device types are especially energy-efficient and silent in partial-load operation.

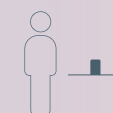

# LAUDA Circulation and process thermostats

## Device type overview

LAUDA LOOP / Page 84

LAUDA PRO / Page 86

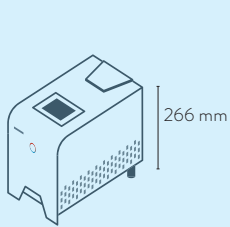

LOOP 100

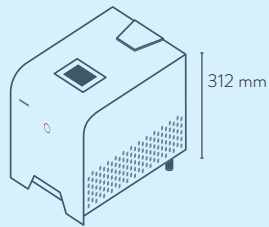

LOOP 250

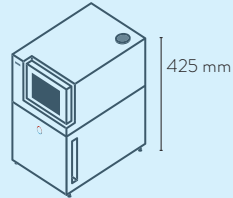

P 2 E

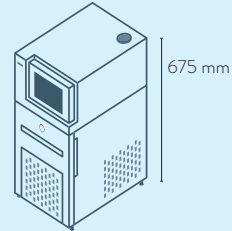

RP 240 EC  
RP 245 EC  
RP 250 EC

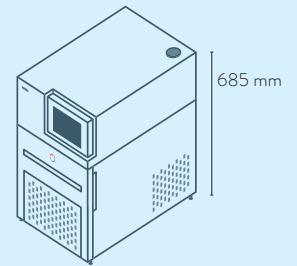

RP 290 EC

LAUDA Integral T / Page 88

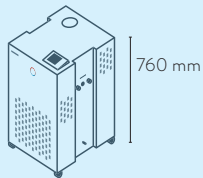

IN 130 T  
IN 230 T  
IN 230 TW

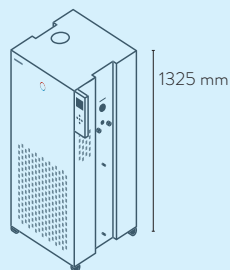

IN 530 T  
IN 530 TW



IN 1030 T



IN 1330 TW  
IN 1830 TW

LAUDA Integral XT / Page 90

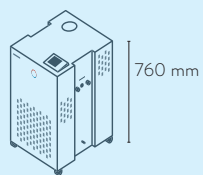

IN 150 XT  
IN 250 XTW  
IN 4 XTW / IN 8 XTW

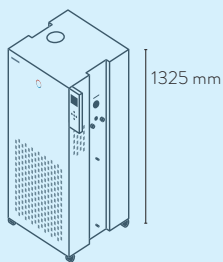

IN 550 XT / IN 550 XTW  
IN 280 XT / IN 280 XTW  
IN 750 XT / IN 950 XTW

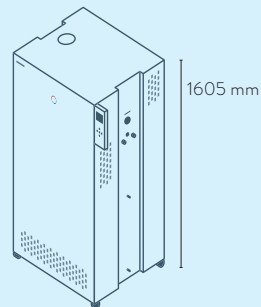

IN 1850 XTW  
IN 590 XTW  
IN 1590 XTW

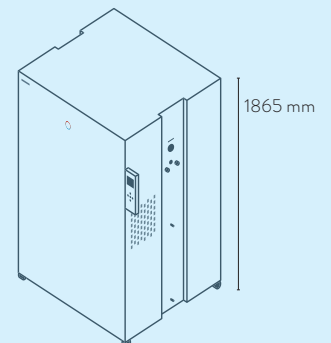

IN 2560 XTW

LAUDA Integral P / Page 92

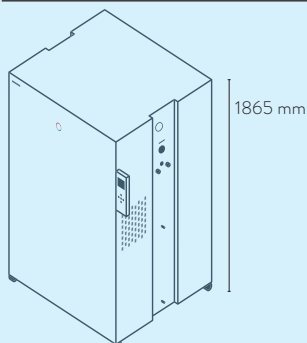

IN 2050 PW  
IN 2560 PW

# LAUDA Circulation and process thermostats

## Function overview

Operating element	Circulation thermostats		Process thermostats		Calibration thermostats		Deep-freezers	
	LOOP	PROE	PROEC	Integral T	Integral XT	Integral P	Integral P	Variocool
Display	OLED	OLED	TFT	TFT	TFT	TFT	TFT	TFT
Mode of operation	3-button softkey	Cursor softkey	Multi-touch	Cursor softkey	Cursor softkey	Cursor softkey	Cursor softkey	Cursor softkey
Removable control	-	✓	✓	Z	Z	Z	-	-
User management	-	-	✓	Operator / Viewer	Operator / Viewer	Operator / Viewer	-	-
Data logging, export to USB stick	-	-	✓	✓	✓	✓	-	-
1-point calibration	✓	✓	✓	✓	✓	✓	✓	✓
2-point calibration	✓	✓	✓	✓	✓	✓	-	-
Self-adaptation controller	-	-	✓	✓	✓	✓	-	-
Safety mode	-	✓	✓	✓	✓	✓	-	-
Programmer, programs/segments	-	1 / 20	100 / 5000	5 / 146	5 / 146	5 / 146	5 / 146	5 / 146
Programmer, tolerance range function	-	✓	✓	✓	✓	✓	✓	✓
Ramp function	-	-	✓	Z	Z	Z	-	-
Timer function	-	-	✓	✓	✓	✓	-	-
Countdown function	-	-	✓	-	-	-	-	-
Graphic temperature profile display	-	-	✓	✓	✓	✓	✓	✓
Pump pressure display (digital)	-	-	-	✓	✓	✓	-	-
Adjustable bypass	-	-	-	✓	✓	✓	✓	✓
Level indicator (digital)	-	✓	✓	✓	✓	✓	✓	✓
Standby timer	✓	✓	✓	✓	✓	✓	✓	✓
Flow control instrument	-	-	-	-	-	-	Z	-
Flow pressure control	-	-	-	-	✓	✓	-	-
Flow measurement + control	-	-	-	-	Z	Z	-	-
Overflow	-	✓	✓	✓	✓	✓	-	-
Low-level alarm	✓	✓	✓	✓	✓	✓	✓	✓
Drain tap	-	✓	✓	✓	✓	✓	✓	✓

Z = Available as an accessory

# LAUDA Circulation and process thermostats

Technical data according to DIN 12876 standard

Device type	Working temperature range °C	Temperature stability ±K	Cooling of the refrigerating machine	Heater power max. kW	Cooling output kW													
					200 °C	100 °C	20 °C	10 °C	0 °C	-10 °C	-20 °C	-30 °C	-40 °C	-50 °C	-60 °C	-70 °C	-80 °C	-90 °C

## LAUDA LOOP / Page 84

LOOP 100	4 ... 80	0.10	Air	0.2	-	-	0.12	0.06	-	-	-	-	-	-	-	-	-	-
LOOP 250	4 ... 80	0.10	Air	0.4	-	-	0.25	0.13	-	-	-	-	-	-	-	-	-	-

## LAUDA PRO / Page 86

P 2 E	80 ... 250	0.05	Water	2.5	-	-	-	-	-	-	-	-	-	-	-	-	-	-
P 2 EC	80 ... 250	0.05	Water	2.5	-	-	-	-	-	-	-	-	-	-	-	-	-	-
RP 240 E	-40 ... 200	0.05	Hybrid	2.5	-	-	0.60 <sup>3</sup>	0.60 <sup>3</sup>	0.60 <sup>3</sup>	0.41 <sup>3</sup>	0.24 <sup>2</sup>	0.12 <sup>2</sup>	0.02 <sup>1</sup>	-	-	-	-	-
RP 240 EC	-40 ... 200	0.05	Hybrid	2.5	-	-	0.60 <sup>3</sup>	0.60 <sup>3</sup>	0.60 <sup>3</sup>	0.41 <sup>3</sup>	0.24 <sup>2</sup>	0.12 <sup>2</sup>	0.02 <sup>1</sup>	-	-	-	-	-
RP 245 E	-45 ... 200	0.05	Hybrid	2.5	-	-	0.80 <sup>3</sup>	0.80 <sup>3</sup>	0.80 <sup>3</sup>	0.53 <sup>3</sup>	0.34 <sup>2</sup>	0.15 <sup>2</sup>	0.04 <sup>2</sup>	-	-	-	-	-
RP 245 EC	-45 ... 200	0.05	Hybrid	2.5	-	-	0.80 <sup>3</sup>	0.80 <sup>3</sup>	0.80 <sup>3</sup>	0.53 <sup>3</sup>	0.34 <sup>2</sup>	0.15 <sup>2</sup>	0.04 <sup>2</sup>	-	-	-	-	-
RP 250 E	-50 ... 200	0.05	Hybrid	2.5	-	-	1.50 <sup>3</sup>	1.44 <sup>3</sup>	1.20 <sup>3</sup>	0.84 <sup>3</sup>	0.54 <sup>2</sup>	0.29 <sup>2</sup>	0.11 <sup>2</sup>	0.02 <sup>1</sup>	-	-	-	-
RP 250 EC	-50 ... 200	0.05	Hybrid	2.5	-	-	1.50 <sup>3</sup>	1.44 <sup>3</sup>	1.20 <sup>3</sup>	0.84 <sup>3</sup>	0.54 <sup>2</sup>	0.29 <sup>2</sup>	0.11 <sup>2</sup>	0.02 <sup>1</sup>	-	-	-	-
RP 290 E	-90 ... 200	0.05	Hybrid	2.5	-	-	0.80 <sup>3</sup>	0.77 <sup>3</sup>	0.74 <sup>3</sup>	0.72 <sup>3</sup>	0.70 <sup>2</sup>	0.68 <sup>2</sup>	0.64 <sup>2</sup>	0.56 <sup>2</sup>	0.39 <sup>2</sup>	0.21 <sup>2</sup>	0.09 <sup>2</sup>	0.01 <sup>1</sup>
RP 290 EC	-90 ... 200	0.05	Hybrid	2.5	-	-	0.80 <sup>3</sup>	0.77 <sup>3</sup>	0.74 <sup>3</sup>	0.72 <sup>3</sup>	0.70 <sup>2</sup>	0.68 <sup>2</sup>	0.64 <sup>2</sup>	0.56 <sup>2</sup>	0.39 <sup>2</sup>	0.21 <sup>2</sup>	0.09 <sup>2</sup>	0.01 <sup>1</sup>

## LAUDA Integral T / Page 88

IN 130 T	-30 ... 120	0.05	Air	2.7	-	1.40	1.40	1.35	1.20	0.80	0.40	0.10	-	-	-	-	-	-
IN 230 T	-30 ... 120	0.05	Air	2.7	-	2.20	2.20	1.90	1.50	1.00	0.60	0.15	-	-	-	-	-	-
IN 230 TW	-30 ... 120	0.05	Water	2.7	-	2.30	2.30	2.30	1.90	1.30	0.75	0.35	-	-	-	-	-	-
IN 530 T	-30 ... 120	0.05	Air	8.0	-	5.00	5.00	4.50	3.80	2.60	1.50	0.60	-	-	-	-	-	-
IN 530 TW	-30 ... 120	0.05	Water	8.0	-	6.00	6.00	5.50	4.50	3.00	1.60	0.70	-	-	-	-	-	-
IN 1030 T	-30 ... 150	0.10	Air	8.0	-	11.00	11.00	9.50	7.10	4.90	3.00	1.60	-	-	-	-	-	-
IN 1330 TW	-30 ... 150	0.10	Water	16.0	-	13.00	13.00	10.00	7.60	5.40	3.40	1.70	-	-	-	-	-	-
IN 1830 TW	-30 ... 150	0.10	Water	16.0	-	19.00	19.00	15.00	11.50	7.50	5.00	2.70	-	-	-	-	-	-

<sup>1</sup>Pump output step 2 <sup>2</sup>Pump output step 4 <sup>3</sup>Pump output step 8

Pump pressure max. bar	Pump flow max. pressure L/min	Pump connection thread mm	Bath volume min. L	Bath volume max. L	Dimensions (W x D x H) mm	Protection Rating	Noise level dB(A)	Weight kg	Loading max. kW	Power supply V; Hz	Part Number	Device type
0.8	2.6	Quick C. 1/4"	0.26	0.28	175×301×266	IP 21	57	7	0.2	100-240 V; 50/60 Hz	L000027	LOOP 100
0.8	2.6	Quick C. 1/4"	0.30	0.32	261×368×312	IP 21	57	12	0.4	100-240 V; 50/60 Hz	L000580	LOOP 250
0.68	22	M16×1	2.4	4.4	250×365×425	IP 21	47	16.5	2.7	200-230 V; 50/60 Hz	L000019	P 2 E
0.68	22	M16×1	2.4	4.4	250×365×425	IP 21	47	17.0	2.7	200-230 V; 50/60 Hz	L000020	P 2 EC
0.68	22	M16×1	2.4	4.4	300×430×675	IP 21	54	41.5	3.7	230 V; 50 Hz	L000021	RP 240 E
0.68	22	M16×1	2.4	4.4	300×430×675	IP 21	54	41.5	3.7	230 V; 50 Hz	L000023	RP 240 EC
0.68	22	M16×1	2.4	4.4	300×430×675	IP 21	54	38.5	3.7	230 V; 50 Hz	L000022	RP 245 E
0.68	22	M16×1	2.4	4.4	300×430×675	IP 21	54	40.0	3.7	230 V; 50 Hz	L000024	RP 245 EC
0.68	22	M16×1	2.4	4.4	300×430×675	IP 21	57	46.5	3.7	230 V; 50 Hz	L002494	RP 250 E
0.68	22	M16×1	2.4	4.4	300×430×675	IP 21	57	47.5	3.7	230 V; 50 Hz	L002495	RP 250 EC
0.68	22	M16×1	2.4	4.4	390×600×685	IP 21	56	76.5	3.7	230 V; 50 Hz	L002502	RP 290 E
0.68	22	M16×1	2.4	4.4	390×600×685	IP 21	56	78.5	3.7	230 V; 50 Hz	L002503	RP 290 EC
3.5	40	G 3/4	3.6	8.7	430×550×760	IP 21	61	79	3.7	230 V; 50 Hz	L002663	IN 130 T
3.5	40	G 3/4	3.6	8.7	430×550×760	IP 21	63	84	3.7	230 V; 50 Hz	L002664	IN 230 T
3.5	40	G 3/4	3.6	8.7	430×550×760	IP 21	60	85	3.7	230 V; 50 Hz	L002665	IN 230 TW
3.5	40	G 3/4	7.2	20.5	560×550×1325	IP 21	66	149	11.0	400 V; 3/PE; 50 Hz & 460 V; 3/PE; 60 Hz	L002666	IN 530 T
3.5	40	G 3/4	7.2	20.5	560×550×1325	IP 21	62	150	11.0	400 V; 3/PE; 50 Hz & 460 V; 3/PE; 60 Hz	L002667	IN 530 TW
5.5	60	M38×1.5	9.7	25.5	760×650×1605	IP 21	70	223	11.0	400 V; 3/PE; 50 Hz & 460 V; 3/PE; 60 Hz	L002668	IN 1030 T
5.5	60	M38×1.5	9.7	25.5	760×650×1605	IP 21	62	225	18.0	400 V; 3/PE; 50 Hz & 460 V; 3/PE; 60 Hz	L002669	IN 1330 TW
5.5	60	M38×1.5	9.7	25.5	760×650×1605	IP 21	67	244	18.0	400 V; 3/PE; 50 Hz & 460 V; 3/PE; 60 Hz	L002670	IN 1830 TW